

# UKC8174NE



<b>Product Family</b>	Refrigerator
<b>Installation</b>	Built-in
<b>Category</b>	Bottom Mount
<b>Built-in niche</b>	178
<b>Reference width</b>	Until 60
<b>Reference height</b>	160 - 200
<b>No-Frost system</b>	Only freezer
<b>Cooling type</b>	Fan assisted refrigerator, no-frost freezer
<b>Defrost</b>	Automatic
<b>Hinge type</b>	Sliding
<b>Hinge position</b>	Right
<b>Reversible door</b>	Yes
<b>EAN code</b>	8017709323936



## Aesthetics



<b>Aesthetics</b>	Universal	<b>Door shelves profile colour</b>	Silver
<b>Colour</b>	White	<b>Drawers profile colour</b>	Silver
<b>Material</b>	Metal sheet	<b>Colour of glass shelf profile</b>	Chrome
<b>Side material</b>	Steel	<b>Display</b>	LCD Touch
<b>Side colour</b>	White	<b>Display position</b>	Interior (on the top)
<b>Logo</b>	Silk screen		

## Refrigerator compartment features



<b>No. of adjustable shelves</b>	2	<b>Type of crisper/vegetable drawers cover</b>	Glass
<b>Number of fruit and vegetables drawers</b>	2	<b>No. of lights</b>	1
<b>Type of adjustable shelves</b>	Glass	<b>Internal light in fridge</b>	Yes
<b>Type of crisper/vegetable drawers cover</b>	Standard	<b>Type of internal light (fridge)</b>	LED
<b>Crisper Cover</b>	Yes		

## Refrigerator Inner Door

<b>No. of door shelves with transparent cover</b>	1	<b>No. of bottle shelves</b>	1
---	---	------------------------------	---

Number of adjustable door shelves 1

## Other Refrigerator features



Accessories Egg tray Fan Yes

## Freezer compartment features

Number of drawers 4

## Other Freezer features

Accessories 1 ice box

## Other technical features



Functions display	Holiday, Fast freezing, Fast cooling
Fast freezing button	Yes
Door open alarm	Yes
Type of temperature control	Electronic
No. of compressors	1
Refrigerant gas type	R600a
Type of compressor	Variable Speed Compressor
Refrigerant Quantity (gr)	55 g
Foam agent	Cyclopentane

## Performance / Energy Label NEW









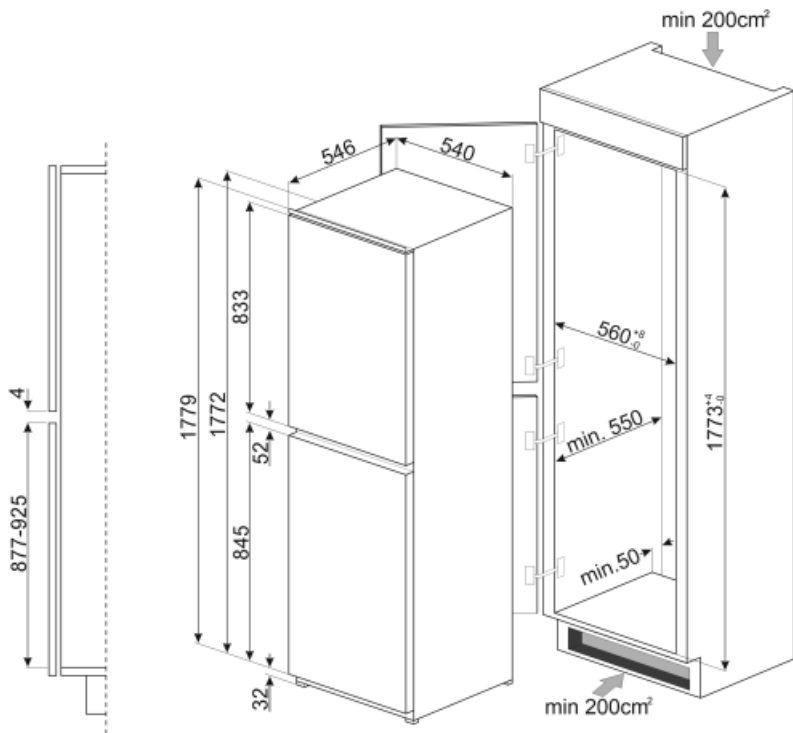



Annual energy consumption	236 KWh/year	Noise level	35 dB(A) re 1pW
Energy efficiency class	E	Thaw time	10.30 h
Airborne acoustical noise emission class	B	4 star - Freezing capacity	8.3 Kg/24h
Total volume	242 l	Climatic class	SN, N, ST, T
Sum of the volumes of the frozen compartment(s)	88 l	EEl	100 %
Sum of the volumes of the chill compartment(s) and the unfrozen compartment(s)	154 l		

## Electrical Connection

Plug	(G) UK e Singapore	Voltage (V)	230-240 V
Nominal power	120 W	Frequency (Hz)	50 Hz
Current	1 A	Power supply cable length	240 cm



## Symbols glossary

	The automatic defrost system works by automatically defrosting at regular intervals eliminating the need to defrost altogether.		Energy efficiency class E
	LCD display: to optimize performance and simplify the use of the appliance.		Ventilated: Forced distribution of cold air in the refrigerator compartment, which allows even temperature distribution within the fridge.
	Fast freezing: The fast freezing function brings the temperature of the compartment down when activated a few hours prior to usage.		Power saving mode: The power saving mode allows you to disable the refrigerator and keep the freezer working.
	LED interior lighting: is a more energy efficient and long lasting way of illuminating the interior of the appliance.		Inverter technology: The evolution of Smeg's driers towards more intelligent and environmentally sustainable models has led to the choice of using Inverter technology with heat pumps, which reduces significantly energy consumption.
	Built-in niche		No Frost: The No Frost and Frost free systems prevent ice from forming so that no defrosting is required.